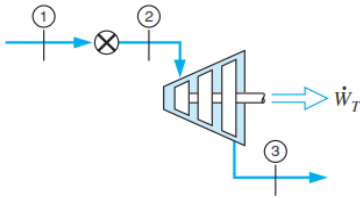
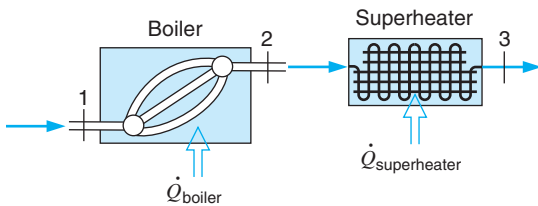


**4.48** A small turbine, shown in Fig. P4.48, is operated at part load by throttling a 0.25-kg/s steam supply at 1.4 MPa and 250°C down to 1.1 MPa before it enters the turbine, and the exhaust is at 10 kPa. If the turbine produces 110 kW, find the exhaust temperature (and quality if saturated).



**FIGURE P4.48**

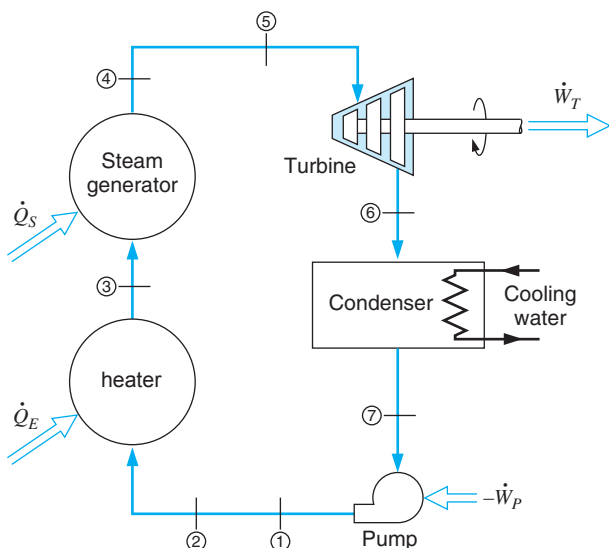
**4.68** Saturated liquid nitrogen at 600 kPa enters a boiler at a rate of 0.008 kg/s and exits as saturated vapor (see Fig. P4.68). It then flows into a superheater also at 600 kPa, where it exits at 600 kPa, 280 K. Find the rate of heat transfer in the boiler and the superheater.



**FIGURE P4.68**

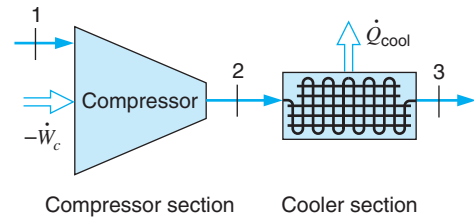
**4.118** The following data are for a simple steam power plant as shown in Fig. P4.118. State 6 has  $x_6 = 0.92$  and velocity of 200 m/s. The rate of steam flow is 25 kg/s, with 300 kW of power input to the pump. Piping diameters are 200 mm from the steam generator to the turbine and 75 mm from the condenser to the heater and steam generator. Determine the velocity at state 5 and the power output of the turbine.

State	1	2	3	4	5	6	7
$P$ , kPa	6200	6100	5900	5700	5500	10	9
$T$ , °C		45	175	500	490		40

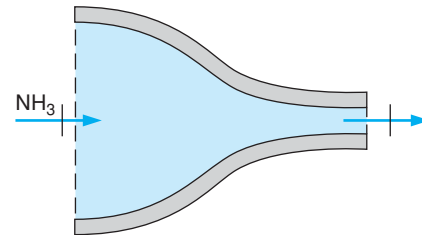


**FIGURE P4.118**

**4.54** A factory generates compressed air from 100 kPa, 17°C by compression to 1000 kPa, 600 K, after which it cools in a constant pressure cooler to 300 K, (see Fig. P4.54). Find the specific compressor work and the specific heat transfer in the cooler.



**4.25** Superheated vapor ammonia enters an insulated nozzle at 30°C, 1000 kPa, as shown in Fig. P4.25, with a low velocity and at a rate of 0.01 kg/s. The ammonia exits at 300 kPa with a velocity of 450 m/s. Determine the temperature (or quality, if saturated) and the exit area of the nozzle.

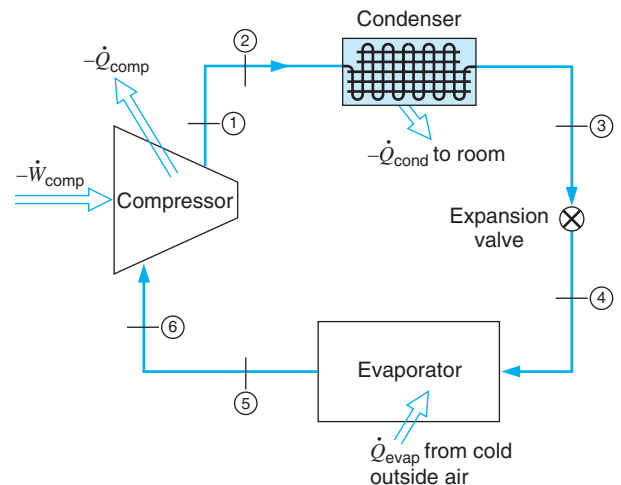


**FIGURE P4.25**

**4.123** An R-410a heat pump cycle shown in Fig. P4.123 has an R-410a flow rate of 0.05 kg/s with 5 kW into the compressor. The following data are given:

State	1	2	3	4	5	6
$P$ , kPa	3000	3000	3000	450	400	390
$T$ , °C	120	110	45		-10	-5

Calculate the heat transfer from the compressor, the heat transfer from the R-410a in the condenser, and the heat transfer to the R-410a in the evaporator.



**FIGURE P4.123**